

**PRECISION
STAIRLIFTS**

Better by Design...

www.PrecisionStairlifts.com

ELEGANCE
Legacy
STAIRLIFT™

“I love my
Legacy Stairlift
for the freedom
& peace-of-mind
it gives me!”



11"
(Folded from wall)



LIMITED
**LIFETIME
WARRANTY**

Features: (both models)

- Folds to within 11" of the wall
- Attaches to stairs, not the wall
- Narrow, low profile track (2.5" tall x 6.5" wide)
- Footrest obstruction sensors with audio beep notification
- Battery power allows 20 trips during power outages
- Top & bottom landing charge stations
- Audio beep notification when unit is not seated on charge stations
- Rocker switch conveniently located on either side of seat
- Constant pressure controls
- Wireless remote controls for upper & lower landings
- Chassis mounted installation load switch
- Quickly installs on left or right side of stairway
- Rack and pinion drive with concealed gear rack
- High seat back
- Low-to-the-floor footrest
- 3" to 6" horizontal extension at top landing
- 25 to 45 degree angle applications
- ETL approved A17.5 / B44 - A18.1
- 350 lbs capacity
- Proudly made in the USA!

Options:

- Embellished upholstery stitching
- **Caramel** or **Walnut** upholstery
- Retractable seat belt - Elegance model only
- **Outdoor package**

NEW



ELEGANCE
Legacy
STAIRLIFT™



ELEGANCE
Legacy
STAIRLIFT™



Remote
Control
Call/Sends

Caramel
Embellished
Upholstery
Stitching
Option

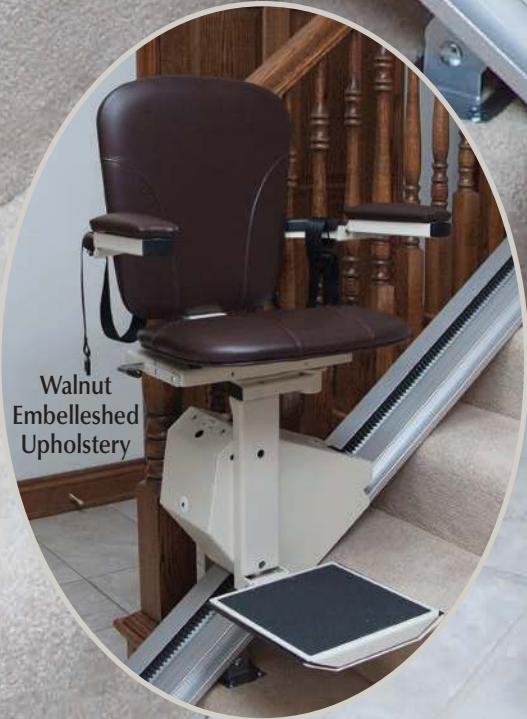

Walnut
Embellished
Upholstery

Technical Information

ELEGANCE
Legacy
STAIRLIFT™

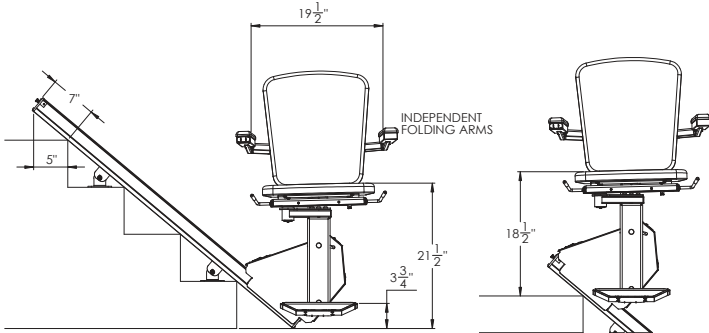
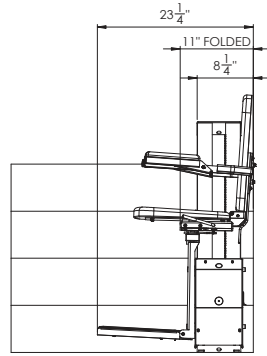

Dimensions subject to change without notice.

Outdoor Model

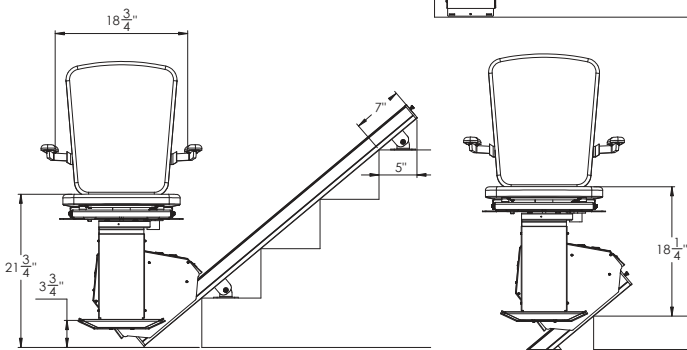
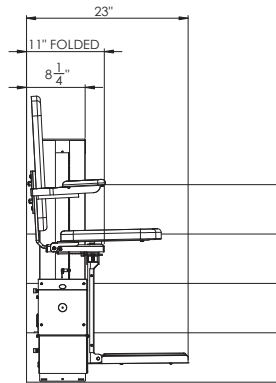

Dimensions subject to change without notice.

Your Precision Dealer:

Best Warranty In The Industry!

INDOOR LIMITED LIFETIME WARRANTY

Lifetime to the original purchaser for:
MOTOR • GEAR • CIRCUIT BOARD

2 Year warranty on BATTERIES
7 Year warranty on PARTS

OUTDOOR WARRANTY

1 Year warranty on BATTERIES
2 Year warranty on PARTS
5 Year warranty on DRIVE TRAIN
& CIRCUIT BOARD



Outdoor package includes
heavy duty cover