

950 Dimensions

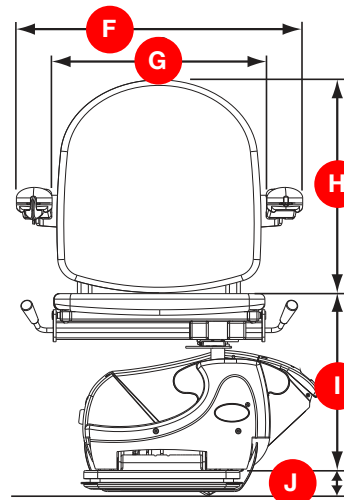

SIMPLICITY SEAT		DIMENSIONS
A	Minimum swivel radius With short armrest	26 ¾" 25 ¾"
B	Wall to inner seat back	3"
C	Seat depth	14 ½"
D	Minimum folded width to footrest	11 ¼"
E	Minimum open width to edge of footrest	22 ⅞"
F	Armrest width – external	23 ¾"
G	Armrest width – internal	18 ¾"
H	Seat back height	15 ¾"
I	Footrest to seat height Standard seat option Extended seat post	15 ⅜" – 19 ¼" 18 ⅞" – 22 ⅞"
J	Minimum footrest height	2"
	Minimum track intrusion into staircase	6 ¼"
	Maximum weight limit Manual hinge or Slide Track	310 lbs 265 lbs

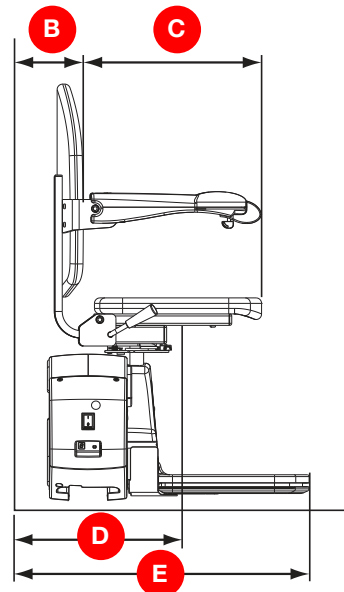
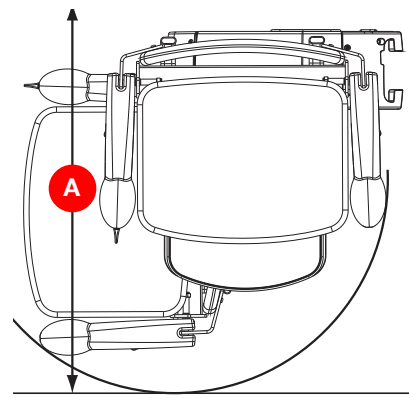
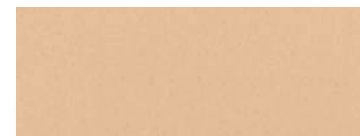

Color Choice: Sand

Upholstery is made from a wipe clean and flame-retardant material.

All of our stairlifts are tested and approved by worldwide independent inspection services to give you the assurance that our products meet the highest standards in terms of quality and safety.

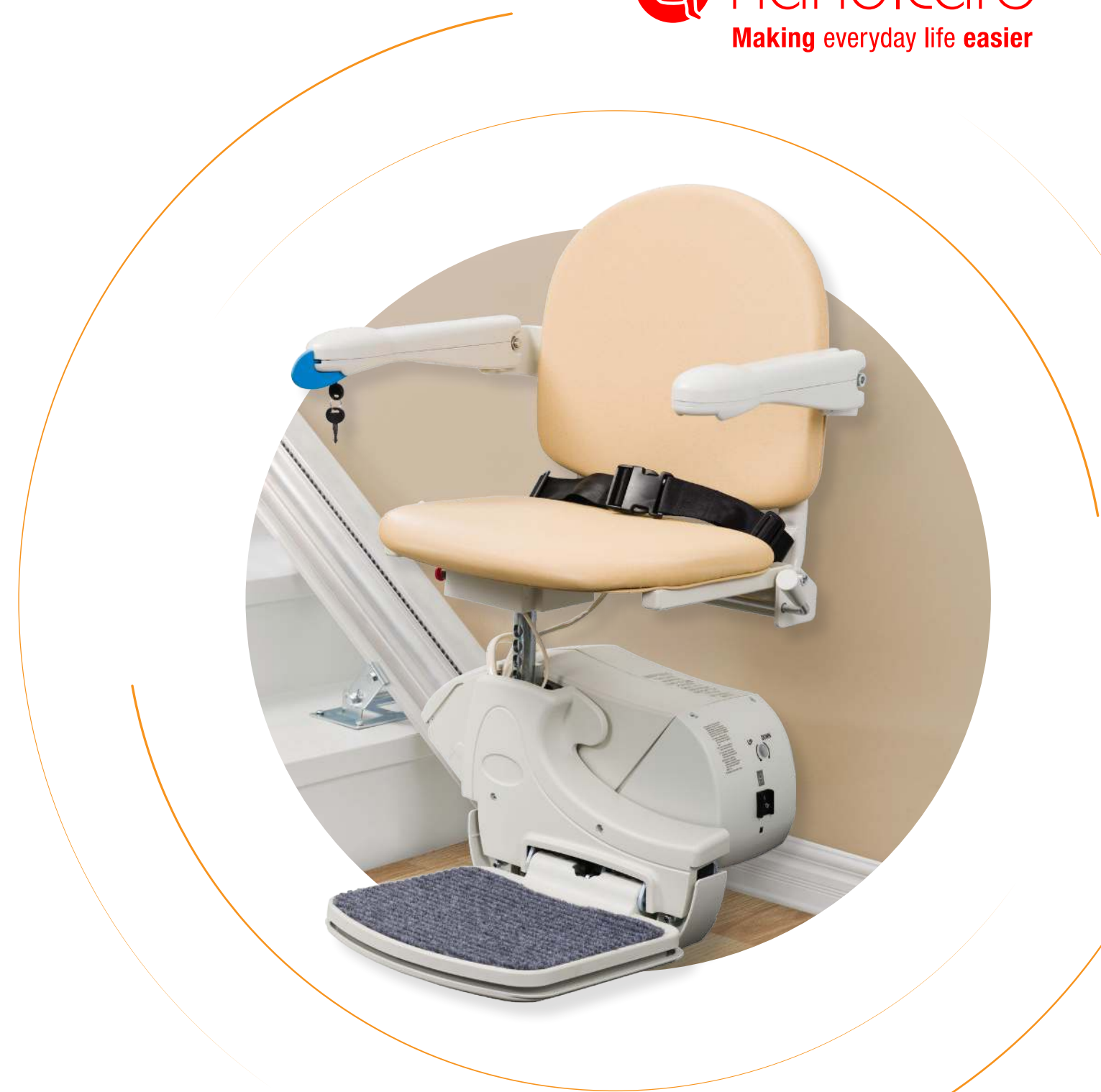

Brought to you locally by:

950

STRAIGHT STAIRLIFT

Our economical, entry level **950** stairlift is everything but. Not only does the 950 get you safely up and down the stairs, but it is designed to get you there with the highest level of convenience. Handicare has been a world leader in innovative lifting and mobility solutions for 130 years, providing safe solutions such as the 950 stairlift.

- Swivel your seat toward the landing for a safer exit when you reach the top
- Each unit comes with 2 handheld remotes to easily retrieve the stairlift
- Prevent unauthorized use with provided key
- Upholstery provided in a sand-colored wipe clean flame retardant fabric
- Limited lifetime warranty on the motor and gearbox; 2 year manufacturer's parts warranty



An innovative and economical solution for your straight staircase

Ergonomic and innovative design features

SMART



Stairlifts are battery powered to ensure you are in motion even during power outage. The **continuous charging feature** charges the battery no matter where it is parked.

SAFE



Surrounded by **safety sensors**, Handicare stairlifts are designed to stop if meeting an obstruction – keeping you safe and still on your seat.

INTUITIVE



The toggle control was designed in collaboration with occupational therapists to ensure it is **easy-to-use** and operate – simply push with your hand, arm or wrist in the direction you want to go.

COMPACT

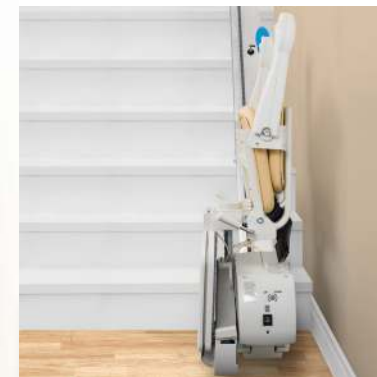

With a foldable footrest, seat and armrests, the 950 boasts a **slim profile** of only 11¼ inches, ensuring other stair users can still use the staircase comfortably and safely.

REVOLUTIONARY



The **Slide Track** moves up the staircase at the same time the seat is moving, leaving the bottom of the stairs completely unobstructed. A manual hinge is also available.

ADAPTABLE



The **zero intrusion** option is used when a doorway close to the top of the stairs would be obstructed by the track. *(This option is not available with the hinge track option.)*

Your first step to independence